

Characteristics:

General Description:

The D5096S is a relay module suitable for the switching of safety related circuits, up to SIL 3 level according to IEC 61508:2010 Ed. 2 for high risk industries. It provides isolation between input and output contacts. A wide compatibility towards different DCS/PLC is guaranteed: driving line pulse testing, executed by DCS/PLC, is permitted by a dedicated internal circuit, to prevent relay and LED flickering. D5096S has 2+2 SPST relay contacts connected in parallel and then in series to avoid spurious trip and to increase availability (see function diagram). High availability SIL 3 Safety Function for NE load or F&G / ND load is available. Load is isolated from supply on both polarities: +/AC, -/AC. Mounting on standard DIN-Rail, with or without Power Bus, or on customized Termination Boards, in Safe Area or in Zone 2.

Load and Line Diagnostic:

Line and load short/open circuit detection is provided, both when the load is off and when the load is on. Presence of load voltage is also monitored, both when the load is off and when the load is on. The fault in the field is directly mirrored to the PLC DO and it is also reported by opening the fault output.

Functional Safety Management Certification:

G.M. International is certified by TUV to conform to IEC61508:2010 part 1 clauses 5-6 for safety related systems up to and included SIL3.



Front Panel and Features:

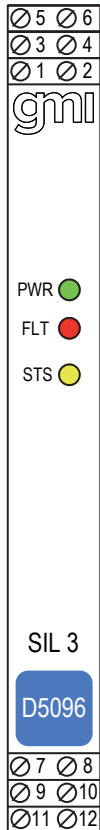

- SIL 3 (low demand mode of operation) for NE Load according to IEC 61508:2010 Ed.2 with Tproof = 14 / 20 yrs ($\leq 10 / >10$ % of total SIF) and PFDavg (1 year) = 7.02 E-06, SFF = 99.36 %.
- SIL 3 (low demand mode of operation) for F&G / ND Load according to IEC 61508:2010 Ed.2 with Tproof = 6 / 20 yrs ($\leq 10 / >10$ % of total SIF) and PFDavg (1 year) = 1.47 E-05, SFF = 97.56 %.
- SIL 3 (high demand mode of operation) for NE Load according to IEC 61508:2010 Ed.2 with PFH = 1.60 E-09 h⁻¹.
- SIL 3 (high demand mode of operation) for F&G / ND Load according to IEC 61508:2010 Ed.2 with PFH = 3.34 E-09 h⁻¹.
- Systematic capability SIL 3.
- Installation in Zone 2.
- Compatible with DCS/PLC pulse testing.
- Line and Load short/open circuit detection.
- Presence of load voltage monitoring.
- The fault in the field is directly mirrored to the PLC DO.
- 5 A high availability to avoid spurious trip SIL 3 contacts for NE or F&G/ND load.
- 6 A inrush current at 24 Vdc / 250 Vac.
- Input/Output/Supply isolation.
- EMC Compatibility to EN61000-6-2, EN61000-6-4, EN61326-1, EN61326-3-1 for safety system.
- ATEX, IECEx, TÜV Certifications.
- TÜV Functional Safety Certification.
- Simplified installation using standard DIN-Rail and plug-in terminal blocks, with or without Power Bus, or customized Termination Boards.

Ordering Information:

Model: D5096S

Power Bus and DIN-Rail accessories:
 Connector JDFT049 Cover and fix MCHP196
 Terminal block male MOR017 Terminal block female MOR022

Technical Data:

Supply: 24 Vdc nom (18 to 30 Vdc) reverse polarity protected, ripple within voltage limits ≤ 5 Vpp, 2 A time lag fuse internally protected.
Current consumption @ 24 V: 15 mA typical.
Power dissipation: 0.35 W typical.
Isolation (Test Voltage): Output/Input 2.5 KV; Output/Supply 2.5 KV; Output/Fault Output 2.5 KV; Input/Supply 500 V; Input/Fault Output 500 V; Supply/Fault Output 500 V.
Input: 24 Vdc nom (21.6 to 27.6 Vdc) reverse polarity protected, ripple within voltage limits ≤ 5 Vpp.
Current consumption @ 24 V: 45 mA.
Power dissipation @ 24 V: 1.1 W.
Output: voltage free 2+2 SPST relay contact (2 paralleled contacts in series) at terminals 7-11 and 8-12, close when relay energized, open in de-energized condition.
Contact material: Ag Alloy (Cd free), gold plated.
Contact rating: 5 A 250 Vac 1250 VA, 5 A 250 Vdc 140 W (resistive load). Min. switching current 1 mA.
Contact inrush current: 6 A at 24 Vdc, 250 Vac.
DC and AC Load breaking capacity:

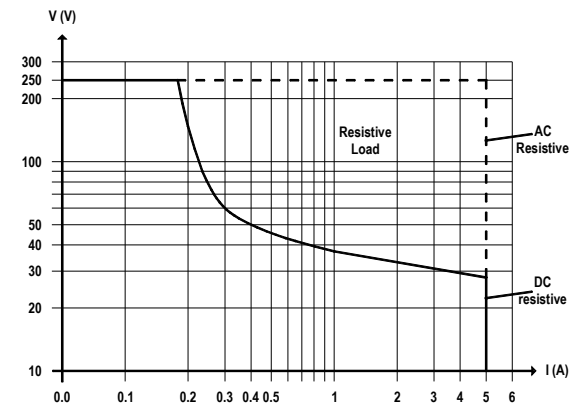

Mechanical / Electrical life: 5 * 10⁶ / 3 * 10⁴ operation, typical.
Operate / Release time: 30 ms / 30 ms typical.
Frequency response: 10 Hz maximum.
Fault detection: see page 2 for details.

Compatibility:

CE mark compliant, conforms to Directive: 2014/34/EU ATEX, 2014/30/EU EMC, 2014/35/EU LVD, 2011/65/EU RoHS.

Environmental conditions:

Operating: temperature limits - 40 to + 70 °C, relative humidity 95 %, up to 55 °C.

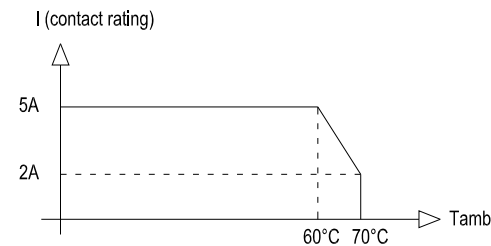

Storage: temperature limits - 45 to + 80 °C.

Safety Description:

CE, Ex, IECEx, ATEX logos.
ATEX: II 3G Ex nA nC IIC T4 Gc.
IECEx: Ex nA nC IIC T4 Gc
 non-sparking electrical equipment.
 -40 °C \leq Ta \leq 70 °C.

Approvals:

BVS 10 ATEX E 114 X conforms to EN60079-0, EN60079-15.
 IECEx BVS 10.0072X conforms to IEC60079-0, IEC60079-15.
 TÜV Certificate No. C-IS-272994-01 SIL 3 conforms to IEC61508:2010 Ed. 2.
 TÜV Certificate No. C-IS-236198-09, SIL 3 Functional Safety Certificate conforms to IEC61508:2010 Ed.2, for Management of Functional Safety.

Mounting: T35 DIN-Rail according to EN50022, with or without Power Bus or on customized Termination Board.

Weight: about 125 g.

Connection: by polarized plug-in disconnect screw terminal blocks to accommodate terminations up to 2.5 mm².

Location: installation in Safe Area or Zone 2, Group IIC T4.

Protection class: IP 20.

Dimensions: Width 12.5 mm, Depth 123 mm, Height 120 mm.

Diagnostic:

Available diagnostic function:

Load status	Load voltage	Load open circuit	Load short circuit	Load to earth leakage	Internal coil short
ON	F	F	F	NA	NA
OFF	F	F	F	NA	NA

F = available function

NA = not available

PF = available function with programmable thresholds

(see smart relay modules for complete programmable diagnostics functions)

Fault detection:

De-energized diagnostic signal: 6.5 V open circuit, 1.3 mA short circuit, typical.

De-energized short output detection: load $R \leq 15 \Omega$

De-energized no short output detection: load $R \geq 25 \Omega$

De-energized open output detection: load $R \geq 21 \text{ K}\Omega$

De-energized no open output detection: load $R \leq 19 \text{ K}\Omega$

Energized short output detection: load $I \geq 6 \text{ A rms}$

Energized no short output detection: load $I \leq 5 \text{ A rms}$

Energized open output detection: load $I \leq 5 \text{ mA rms}$

Energized no open output detection: load $I \geq 15 \text{ mA rms}$

Load Supply fault detection: load voltage $\leq 5 \text{ V rms}$

Load Supply no fault detection: load voltage $\geq 20 \text{ V rms}$

Fault signalling: voltage-free NE SPST solid-state relay contact
(output de-energized in fault condition).

Output rating: 100 mA 35 V ($\leq 1 \text{ V}$ voltage drop)

Response time: <500 ms typical.

Image:



Function Diagram:

SAFE AREA, ZONE 2 GROUP IIC T4

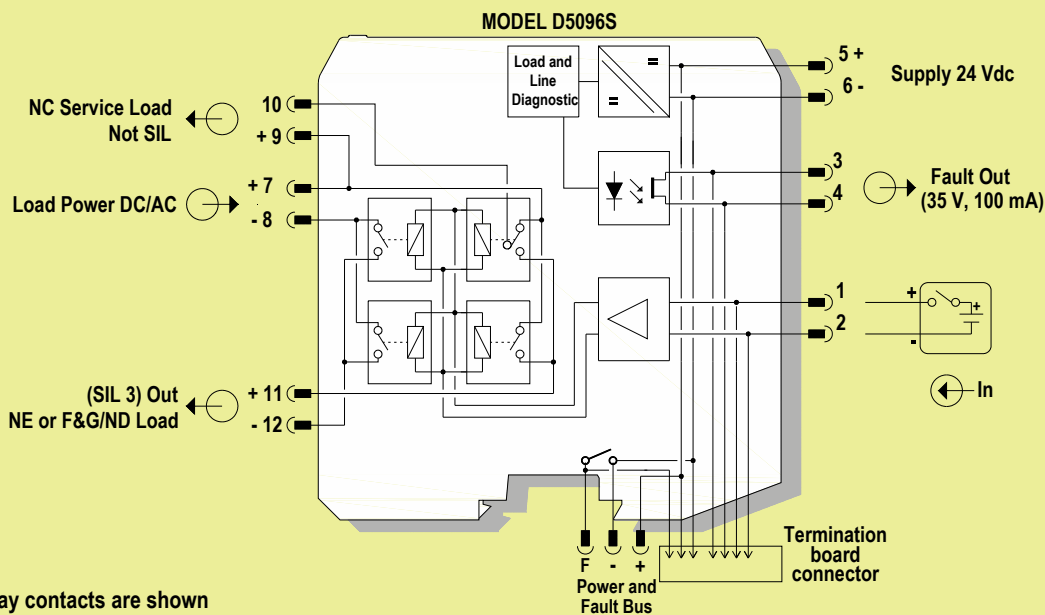

All relay contacts are shown
in de-energized position

To prevent relay contacts from damaging, connect an external protection (fuse or similar), chosen according to the relay breaking capacity diagram.

See the following pages for Functional Safety applications with related SIL value.

Application for D5096S - SIL 3 for NE Load with bipolar load interruption

Normal state operation

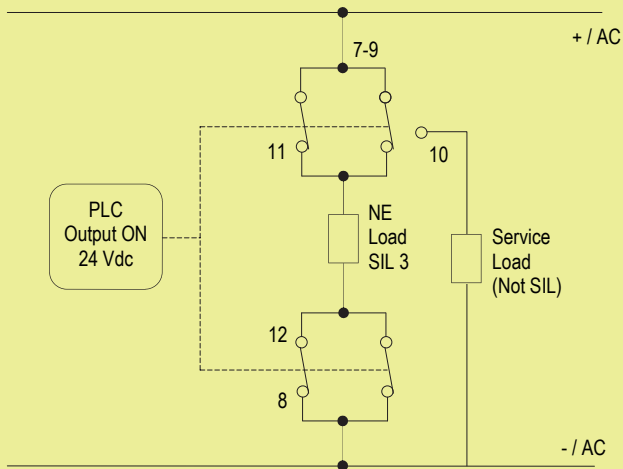

Contacts 7-11 and 8-12: in normal operation the relay is energized, contacts are closed, load is energized.
Contact 9-10: in normal operation relay is energized, contact is open, service load for NE load is de-energized.

De-energized to trip operation

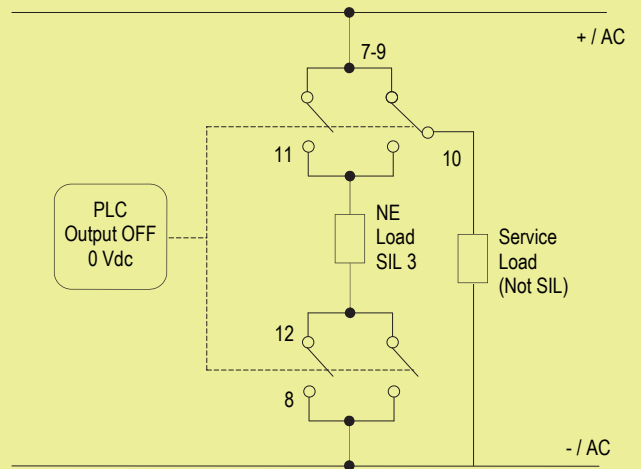

Contacts 7-11 and 8-12: the SIL 3 Safety Function is met when the relay is de-energized, contacts are open, load is de-energized.
Contact 9-10: in safe state the relay is de-energized, contact is closed, service load for NE load is energized.

Application for D5096S - SIL 3 for F&G/ND Load with bipolar load interruption

Normal state operation

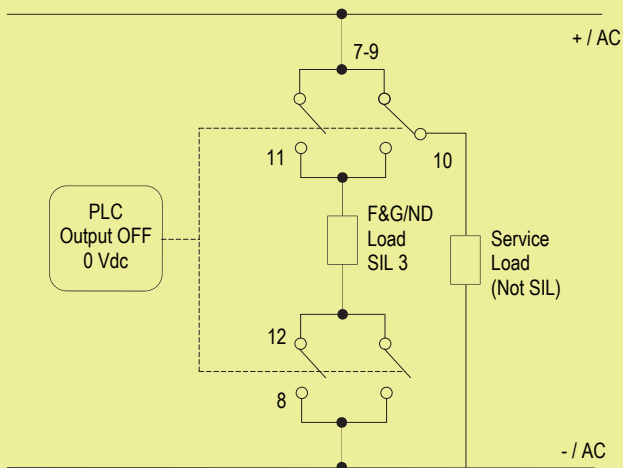

Contacts 7-11 and 8-12: in normal operation the relay is de-energized, contacts are open, load is de-energized.
Contact 9-10: in normal operation relay is de-energized, contact is closed, service load for F&G/ND load is energized.

Energized to trip operation

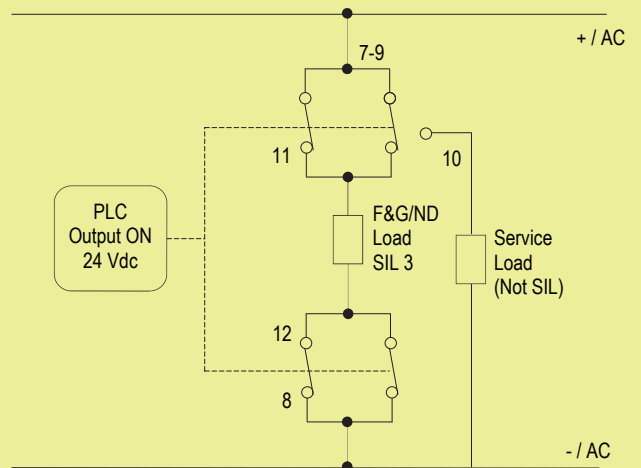

Contacts 7-11 and 8-12: the SIL 3 Safety Function is met when the relay is energized, contacts are closed, load is energized.
Contact 9-10: in safe state the relay is energized, contact is open, service load for F&G/ND load is de-energized.